

## PRODUCT DETAILS

The DAB102M is a cast iron, self-priming centrifugal pressure pump with excellent suction capacity even when there are air bubbles in the water.

Particularly suited to water supply in domestic installations, small-scale agriculture, gardening and wherever self-priming operation is required.

DAB Jet pumps are renowned for their unique self priming and extraordinary deep suction capability; up to 8 metres at sea level.



## APPLICATIONS

- Household water supply - medium to larger dwellings
- Light garden irrigation
- Water transfer
- Washing systems
- Pressure boosting

## FEATURES

- Motor support in cast iron, technopolymer impeller, diffuser, Venturi tube and sand guard. Stainless steel adjustment rings.
- Carbon/ceramic mechanical seal.
- Asynchronous motor closed and cooled by external ventilation. Max Ambient temp 40 deg C
- Built-in thermal and current overload protection and a capacitor permanently on in the single-phase versions.

## TECHNICAL DATA

<b>OUTPUT POWER (KW)</b>	0.75kW P2
<b>MAX. HEAD [M]</b>	53.8M
<b>MAX. FLOW L/MIN</b>	60 l/min
<b>MAX PRESSURE</b>	6 bar
<b>LIQUID TEMPERATURE</b>	2 - 35 deg C
<b>MOTOR</b>	Asynchronous TEFC
<b>MOTOR INSULATION</b>	F Class insulation
<b>MOTOR PROTECTION</b>	In-built thermal overload
<b>PROTECTION CLASS</b>	IP44. Terminal board I.P.55

<b>RATED VOLTAGE</b>	220 - 240V 1Ph 50 Hz
<b>RATED CURRENT</b>	5.1A
<b>CAPACITOR</b>	16uF 450V
<b>POWER CABLE</b>	2m long 10 amp rated H05 flex 10 amp 3 pin plug
<b>PUMP BODY</b>	Cast iron 200 UNI ISO 185
<b>INTERNALS</b>	Technopolymer A
<b>MECHANICAL SEAL</b>	Carbon/Ceramic
<b>PACKAGE DIMENSION</b>	L470 x W240 x H240mm
<b>GROSS WEIGHT (KG)</b>	12.5kg

## CURVE

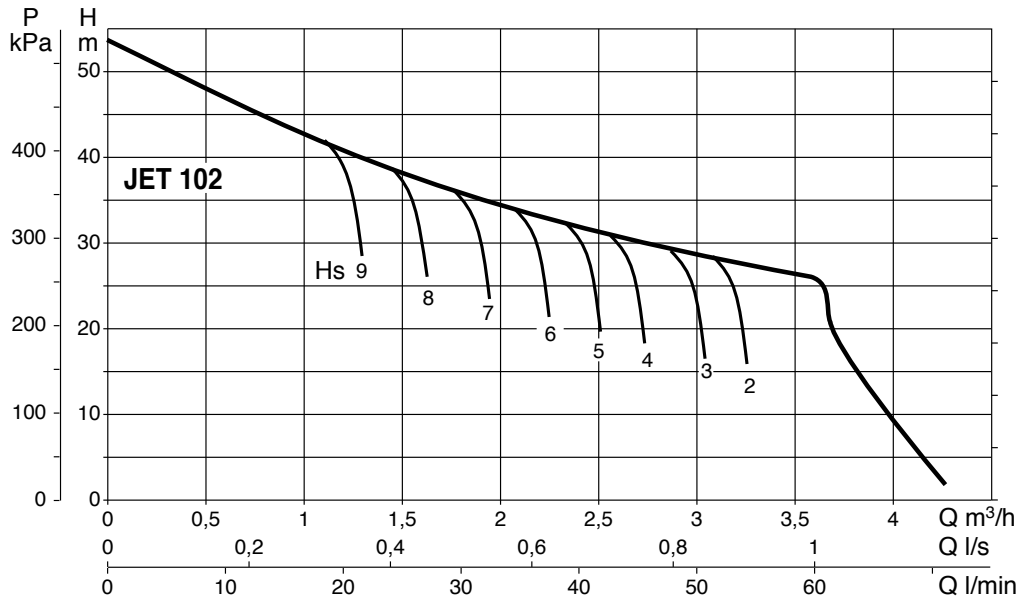

## DIMENSIONS

A	414
A1	409
B	178
C	108
E	197
F	14
G	111
H	203
H3	144
I	Dia 9
DNA	1" GAS
DNM	1" GAS

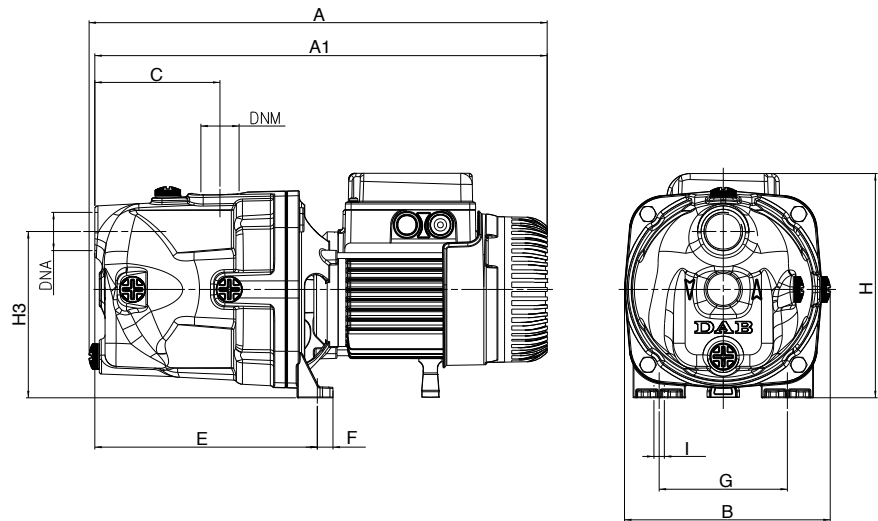

## WARRANTY / CERTIFICATIONS

